

LARGE EXCAVATOR

SY750H

STANDARD FEATURES

- ➔ Dual swing drives
- ➔ 1-way and 2-way primary auxiliary and 2-way secondary auxiliary circuits with dedicated auxiliary rotate pump
- ➔ 10.4" touchscreen display
- ➔ Heated air ride seat with adjustable independent control positions
- ➔ Blind side and rear view cameras
- ➔ Powerful Cummins Engine

391 kW

Gross Power

7,580 mm

Dig Depth

80,850 kg

Operating Weight

410.0 kN

Bucket Breakout Force

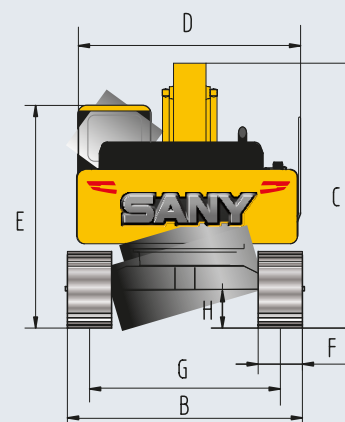
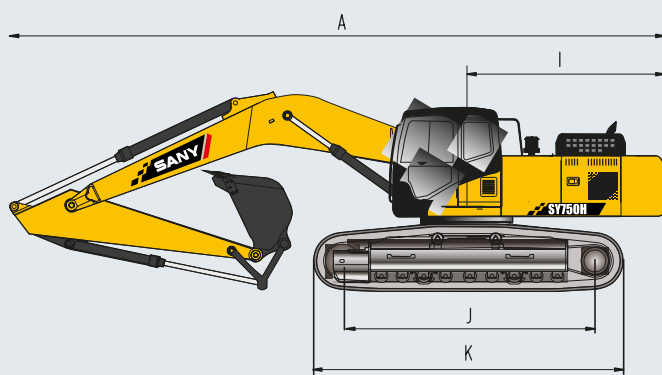

TECHNICAL SPECIFICATIONS

TECHNICAL SPECIFICATIONS

Operating Weight	80850 kg
Ground Pressure	101.0 kPa
Engine	Cummins X15 Stage V
Displacement	14.9 L
Gross Power	391 kW
Hydraulics	Positive Flow w/Pilot Control
Main Hydraulic Pump	Axial Piston – Variable Displacement
Operating Flow (maximum) 2@504 L/min	1008.0 L/min
Operating Pressure (maximum)	34.3 MPa
Travel Pressure (maximum)	34.3 MPa
Slew Pressure	28.5 MPa
Pilot Pressure	3.9 MPa
Travel Motor	Axial Piston with Park Brake
Travel Pressure (maximum)	34.3 MPa
Travel Speeds (maximum)	2.9 / 4.5 km/hr
Travel Effort (maximum)	546.8 kN
Grade Capability (maximum)	35°
Swing Motor	Axial Piston with Swing Brake
Swing Pressure (maximum)	28.5 MPa
Swing Speed (maximum)	7.2 RPM
Undercarriage (standard)	Steel Track
Track Width (standard)	650 mm
Track Rollers (per side)	8
Carrier Rollers (per side)	3

DIMENSIONS

DIMENSIONS

Boom Length	7000 mm
Dipper Length	3000 mm
A Transport Length	12879 mm
B Transport Width	3499 mm
C Transport Height	4981 mm
D Upper Structure Width (with step)	4479 mm
E Cab Height	3795 mm
F Track Width (standard shoe)	650 mm
G Track Gauge	3380 mm
H Ground Clearance	892 mm
I Tail Swing Radius	4175 mm
J Track Length on Ground	4770 mm
K Track Length	5986 mm

SERVICE REFILL CAPACITIES

Fuel Tank Capacity	940.0 L
DEF Tank Capacity	100.0 L
Hydraulic Tank Capacity	680.0 L
Engine Oil Capacity	36.5~43 L
Cooling System Capacity	75.0 L

*Based on theoretical calculation at max Flow with no load. Subject to alterations. In the interest of continual equipment development



STANDARD AND OPTIONAL EQUIPMENT

s = standard / o = optional

SY750H	ENGINE
s	14.9l Cummins X15
s	Auto-idle
s	Dual-element dry air filter
s	Batteries 24V (2-12V)
s	Coolant Expansion tank
s	Electronic engine control
s	Enclosed fan guard
s	Engine coolant to -37 deg. C (-34 deg. F)
s	Fuel filter with water separator
s	Full-flow oil filter
s	Turbocharger with charge air cooler
s	High flow electric clutch actuated fan
s	500-hour engine-oil-change interval
s	70% (35 deg.) off-level capability
s	Engine air precleaner
s	Severe-duty fuel filter
	HYDRAULIC SYSTEM
s	Spring-applied, hydraulically released automatic swing brake
s	Auxiliary hydraulic-flow adjustments through monitor
s	Lift power boost on joystick
s	Control pattern change valve
s	Auxiliary hydraulics with 1 and 2-way combination piping for high flow
s	Auxiliary hydraulics with 2-way rotation piping and controls
s	Auxiliary pilot and electric controls
s	Quick coupler plumbing and control
	UNDERCARRIAGE
s	Planetary drive with axial piston motors
s	Propel motor shields
s	Spring-applied, hydraulically released automatic propel brake
s	Track guides, front idler and 2 additional per side
s	2-speed travel selection
s	Upper carrier rollers (3)
s	Sealed and lubricated track chain
s	Double semi-grouser shoes, 650 mm (25.6")
s	Undercarriage frame opening guard
	BOOM & DIPPER
s	Boom 7.0 m
s	Dipper 3.0 m
	UPPERSTRUCTURE
s	Right-hand, left-hand
o	Counterweight mirrors
s	Vandal lock with ignition key: Cab door / Service door / Toolbox / Cab Filter
s	Debris screen in side panel
s	Remote-mounted engine oil and fuel filters
s	Heavy duty triangle channel frame guard
	ATTACHMENTS
s	Convenient grease points
o	Centralized lubrication system

In the interest of continual equipment development, SANY reserves the right to change these specifications at any time without prior notification.



STANDARD AND OPTIONAL EQUIPMENT

s = standard / o = optional

SY750H	ATTACHMENTS CONTINUED
s	Dirt seals on all bucket pins
s	Oil-impregnated bushings
s	Reinforced resin thrust plates
o	Quick coupler
o	Buckets: Heavy duty / Heavy-duty high capacity / Side cutter and teeth
	OPERATOR'S STATION
s	Adjustable independent-control positions (levers-to-seat, seat-to-pedals)
s	AM/FM radio with USB charging and Bluetooth® connectivity
s	Auto climate control/air conditioner/heater/pressurizer
s	Built-in Operator's Manual storage compartment and manual
s	12V and 24V outlets 60 watt 5 amp
s	Deluxe heated air suspension cloth seat with adjustable armrests
s	Heavy duty rubber floor mat
s	Front windshield wiper with intermittent speeds
s	Touchscreen Monitor 10". Displays Fuel, DEF, Engine temp, Oil temp.
s	Horn, electric
s	Hour meter, electric. In touch screen.
s	Hydraulic shutoff lever, all controls
s	Interior light
s	Digital Power mode selection: 3 power modes- low, standard, and high
s	Digital tool selection: bucket, shear, hammer, etc.
s	Multifunction color LCD monitor with: Diagnostic capability / Multiple-language / Maintenance tracking / Clock
s	System monitoring with alarm features: Auto-idle indicator, engine air cleaner restriction indicator light, engine check, engine coolant temperature indicator light with audible alarm, engine oil pressure indicator light with audible alarm, low-alternator-charge indicator light, low-fuel indicator light, low DEF indication with audible alarm, fault code alert indicator, fuel-rate display, wiper-mode indicator, work-lights-on indicator, and work-mode indicator
s	Motion alarm with cancel switch (conforms to SAE J994)
s	Power-boost switch on right joystick
s	Auxiliary hydraulic control switches in right console lever
s	Seat belt, 2", non-retractable
s	Transparent overhead hatch
s	Heated or cooled food/beverage storage
s	Air-suspension heated seat
s	Hydraulic oil filter restriction indicator light
o	Protection screens for cab front, rear, and side
	ELECTRICAL
s	60-amp alternator
s	Ground level electrical disconnect (lockout tag out)
s	Blade-type multi-fused circuits
s	Positive-terminal battery covers
s	Rearview camera
	LIGHTS
s	Work lights: High power LED - 4 mounted on boom, 2 mounted on top of cab, 1 mounted under step on right side of machine , Green beacon, Orange beacon

SANY HEAVY MACHINERY (UK) LTD
 info@sanyuk.com
 www.sanyuk.com



SANY UK

sanyuk.com

PRODUCT SPECIFICATIONS

LARGE EXCAVATOR || SY750H

WORKING RANGE

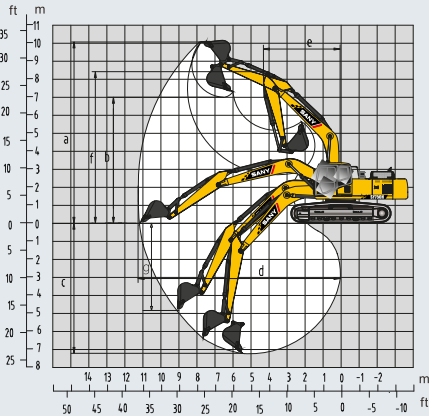

WORKING RANGE

Boom Length	7000 mm
Dipper (Arm) Length	3000 mm
A Maximum Digging Height	11020 mm
B Maximum Dumping Height	7170 mm
C Maximum Digging Depth	7580 mm
D Maximum Vertical Wall Digging Depth	4890 mm
E Maximum Reach at Ground Level	12100 mm
F Minimum Swing Radius	5390 mm

DIGGING PERFORMANCE

Boom Length	7000 mm
Dipper (Arm) Length	3000 mm
Bucket Breakout Force (ISO)	410.0 kN
Dipper Tearout Force (ISO)	354.0 kN

LIFTING PERFORMANCE

Standard 7000 mm Boom
Standard 3000 mm Dipper
Standard 650 mm Tracks
No Bucket

Ratings are based on ISO 10567:200 7. Lift capacity does not exceed 75% of tipping load with the machine on firm, level ground or 87% of hydraulic lifting capacity.

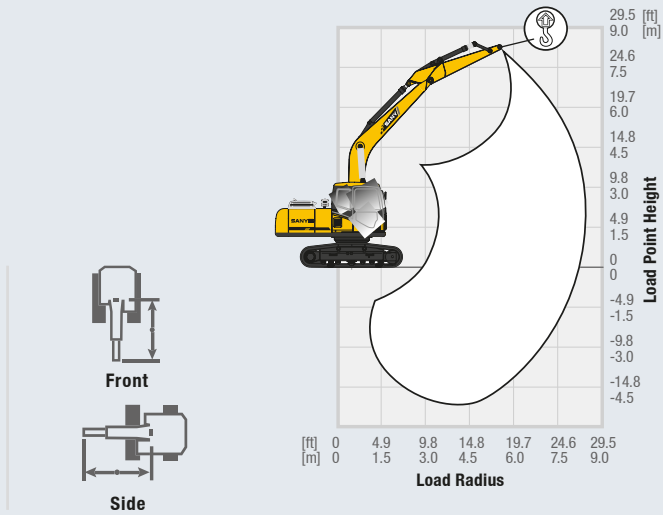

LOAD RADIUS	4.9 FT 1.5 M	9.8 FT 3.0 M	14.8 FT 4.5 M	19.7 FT 6.0 M	24.6 FT 7.5 M	29.6 FT 9.0 M	HORIZONTAL MAX REACH						
LOAD POINT HEIGHT	[Diagram]		[Diagram]		[Diagram]		[Diagram]		[Diagram]		ft mm		
29.6 ft 9.0 m							38017 lbs 17244 kg	38017 lbs 17244 kg	24.2 ft 7388 mm				
24.6 ft 7.5 m					37340 lbs 16937 kg	37340 lbs 16937 kg			36608 lbs 16605 kg	36608 lbs 16605 kg	27.8 ft 8481 mm		
19.7 ft 6.0 m				68917 lbs 31260 kg	58453 lbs 26514 kg	39194 lbs 17778 kg	39194 lbs 17778 kg	36286 lbs 16459 kg	36286 lbs 16459 kg	36149 lbs 16397 kg	36149 lbs 16397 kg	30.2 ft 9200 mm	
14.8 ft 4.5 m				50753 lbs 23021 kg	50753 lbs 23021 kg	42177 lbs 19 131 kg	42177 lbs 19 131 kg	37364 lbs 16 948 kg	37364 lbs 16948 kg	36143 lbs 16394 kg	30801 lbs 13971 kg	31.6 ft 9630 mm	
9.8 ft 3.0 m				56562 lbs 25656 kg	56562 lbs 25656 kg	45279 lbs 20538 kg	45279 lbs 20538 kg	38801 lbs 17600 kg	33204 lbs 15061 kg	36359 lbs 16492 kg	29273 lbs 13278 kg	32.2 ft 9811 mm	
4.9 ft 1.5 m				60144 lbs 27281 kg	60144 lbs 27281 kg	47532 lbs 21560 kg	47532 lbs 21560 kg	39813 lbs 18059 kg	32463 lbs 14725 kg	36804 lbs 16694 kg	29070 lbs 13186 kg	32.0 ft 9756 mm	
0 ft 0 m			64946 lbs 29459 kg	64946 lbs 29459 kg	60737 lbs 27550 kg	60737 lbs 27550 kg	48178 lbs 21853 kg	41026 lbs 18609 kg	39635 lbs 17978 kg	32020 lbs 14524 kg	37247 lbs 16895 kg	30005 lbs 13610 kg	31.0 ft 9461 mm
-4.9 ft -1.5 m		47763 lbs 21665 kg	47763 lbs 21665 kg	74567 lbs 33 823 kg	74567 lbs 33823 kg	58359 lbs 26471 kg	58359 lbs 26471 kg	46562 lbs 21120 kg	46562 lbs 21120 kg		37545 lbs 17030 kg	37545 lbs 17030 kg	29.2 ft 8903 mm
-9.10 ft -3.0 m		80885 lbs 36689 kg	80885 lbs 36689 kg	65859 lbs 29873 kg	65859 lbs 29873 kg	52525 lbs 23825 kg	52525 lbs 23825 kg	41326 lbs 18745 kg	41326 lbs 18745 kg		37379 lbs 16955 kg	37379 lbs 16955 kg	26.3 ft 8024 mm
-14.8 ft -4.5 m				51575 lbs 23394 kg	51575 lbs 23394 kg	40766 lbs 18491 kg	40766 lbs 18491 kg				35719 lbs 16202 kg	35719 lbs 16202 kg	22.0 ft 6698 mm

Based on theoretical calculation at max flow with no load. Subject to alterations. In the interest of continual equipment development, SANY reserves the right to change these specifications at any time without prior notification.

