

SY215E

ELECTRIC EXCAVATOR

Max. Gross Power
150 kW / 1,800 rpm

Operating Weight
23,200 kg

Max. Dig Depth
6,255 mm



SANY:

QUALITY CHANGES THE WORLD

Founded in 1989, SANY has grown into one of the world's largest construction equipment manufacturers, with global R&D and production – including European facilities – and machines working in 150+ countries. Our range spans excavators, road and port machinery, and cranes, built with proven manufacturing heritage and modern quality systems.

A GLOBAL LEADER BEHIND EVERY RANGE

From compact excavators to high-tonnage earthmovers, cranes, telehandlers, concrete machinery, road equipment and more, SANY's worldwide product range reflects decades of innovation, investment, and real-world experience.

This broad international range is proven on job sites in over 150 countries, ensuring every machine delivered to Europe is backed by extensive testing, real-world performance and the strength of a global supply chain.

ENGINEERED FOR OUR EUROPEAN CUSTOMERS

Every SANY machine destined for Europe is engineered to meet European regulations and real-world use cases – from CE and Stage V compliance to region-specific specifications and options.

For European construction customers, this worldwide capability translates directly into trust. SANY selects and engineers its product line specifically for local requirements, combining global innovation with European-quality standards, dealer support and service.

GLOBAL MANUFACTURING EXCELLENCE

SANY's long-standing commitment to quality and innovation – supported by advanced intelligent manufacturing and a sustained 5-7% of annual revenue reinvested into R&D – results in machines that deliver reliability, efficiency, and consistent performance on site.

With state-of-the-art production facilities and rigorous global testing standards, every machine is built to withstand demanding conditions and deliver long-term value.

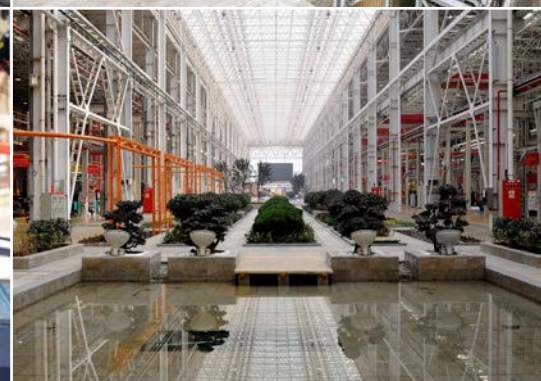
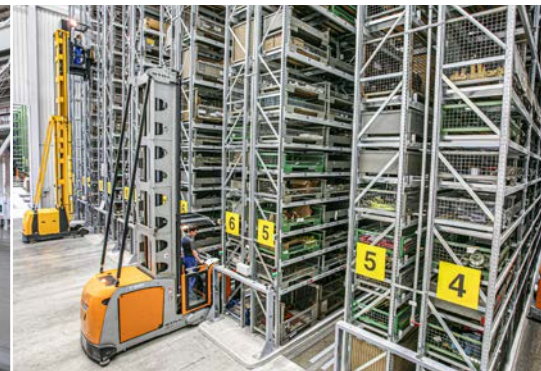

INTRODUCING THE SY215E

The 23-tonne SANY SY215E electric excavator is built to deliver more for your business, zero emissions for cleaner sites, ultra-low noise for working in sensitive environments, and lower running costs thanks to reduced maintenance.

Powered by an advanced cobalt-free lithium-iron phosphate battery, it gives you reliable, consistent performance throughout the day. Flexible CCS2 automotive-standard charging makes it easy to integrate into your operation, while a single charge delivers up to a full working shift of 5–8 hours.

The result? A machine that keeps your projects moving, your costs down, and your operation ready for the future.



WHY CHOOSE SANY EXCAVATORS



WORLD RENOWNED COMPONENTS

SANY uses proven, top-tier components to deliver long-lasting reliability – meaning you benefit from fewer breakdowns, longer service life, and lower ownership costs.



GREAT VALUE, UNCOMPROMISED QUALITY

You can have confidence in your return on investment. SANY excavators are loaded with the latest innovations to help reduce costs, increase productivity and protect resale value.



INDUSTRY LEADING 5 YEAR WARRANTY

Built to last – and backed by an industry-leading warranty – giving you lower risk, predictable costs, and confidence on every job.



LOW OPERATING COSTS

Simple engineering, readily available parts, and long lasting batteries reduce ongoing running costs – a major advantage in Europe's high-cost markets.



LOCAL SUPPORT

Europe-wide expert dealers and value-added aftermarket support keep your machine running, minimise downtime, and simplify ownership.



STANDARD ADVANCED FEATURES

SANY excavators include all essential features as standard – no costly add-ons or custom tweaks required.

SY215E

PRODUCTIVITY

The SY215E fully electric excavator keeps your productivity high and your projects moving. With zero emissions and ultra-low noise, you can work where others can't, indoors, in urban areas, or out of hours, maximising utilisation and reducing downtime. High-performance hydraulics, twin auxiliary lines and a hydraulic quick hitch let you switch attachments fast and stay versatile, while two-speed tracking keeps you efficient on every job.



GREATER SITE OPPORTUNITIES

← With zero emissions and ultra-low noise operation, the SY215E opens up opportunities to work in restricted environments such as indoors, urban areas, or during out-of-hours periods, helping you increase machine utilisation.

Best-in-class pump, valve block and slew motors deliver maximum efficiency and performance, helping you get more work done in less time.

HYDRAULICS DESIGNED FOR PRODUCTIVITY

→ SANY's twin auxiliary hydraulics as standard allow you to operate a wider range of attachments with powered movement in both directions, giving you reversible control and faster task changes.

SANY's hydraulic quick hitch enables in-cab attachment changes within seconds, eliminating manual pin removal, reducing exposure to pinch points, and minimising downtime between tasks.

VERSATILE OPERATION

Equipped with standard hammer and bi-directional pipework, the SY215E is ready to run a wide range of attachments for maximum on-site versatility.

SANY's two speed tracking allows the operator to switch between high and low speeds based on the terrain and task.



SY215E

ZERO EMISSIONS, MINIMAL DISRUPTION

The fully electric SY215E combines zero-emission performance with fast, flexible charging and up to 5–8 hours of run time from a single charge. It lets you work in emission-sensitive areas while benefiting from instant torque and precise control for improved productivity. With fewer service components and reduced maintenance requirements, it also helps lower running costs and maximise uptime across every job.



EXTENDED RUN TIME

The SY215E delivers up to 5–8 hours of run time on a single charge, giving you the flexibility to complete a full working shift while reducing the need for recharging, depending on application and operating conditions.

LONG-LIFE OPERATION

Our advanced battery technology is engineered for long-term durability, delivering sustained performance year after year. A longer battery lifespan helps reduce total cost of ownership and protects long-term residual value.

CHARGE EFFICIENCY

With an automotive-grade CCS2 DC charging socket as standard, the machine supports rapid charging in as little as 1.5 hours using a 320 kW dual gun fast charger, keeping downtime to a minimum. For added flexibility, it can also be charged via an industrial 3-phase 63 Amp (40 kW) supply, achieving a full charge in approximately 8–10 hours.

MINIMAL DISRUPTION

Ultra-low noise levels of 71 dB(A) inside and 97 dB(A) outside the machine allows work in residential areas, indoors, and during early mornings or late evenings with minimal disruption.



SY215E

OPERATOR ENVIRONMENT

The electric SY215E excavator is built to help your operators stay comfortable, focused and productive throughout the day. With an ergonomic cab, intuitive controls and a climate-controlled environment, it reduces fatigue and supports efficient working, helping you get more done with ease on every job.



EVERYDAY EASE

➔ Clear instrumentation and a high-resolution 10" touch screen colour display make machine operation easier and more intuitive, helping operators work with confidence and precision.

Standard dual proportional joysticks ensure precise, intuitive control, helping operators work faster, safer and more efficiently with any attachment.

For added comfort and practicality, the SY215E features a bluetooth radio, USB socket, sun shade and generous storage for operator convenience.



JOB SITE AWARENESS

All-round mirrors provide clear visibility of the surrounding workspace, improving operator awareness and safety on site.

Large windows and an intelligently engineered cab give operators clear, all-round visibility, helping improve safety, precision and confidence on every job.

PREMIUM COMFORT

➔ The ergonomic operator's cab of the SY215E excavator features a heated, air-suspension seat and adjustable armrests, designed to keep operators comfortable, focused, and productive.

A standard-fit heater and automatic air-conditioning keeps the cab warm and comfortable, ensuring operators remain productive in all weather conditions.

Low noise levels of just 71 dB(A) inside the cab and 97 dB(A) outside, as well as low vibration levels, help keep operators comfortable and reduce fatigue, while making communication clearer and safer across the site.

SY215E

SAFETY & SECURITY

From reinforced structural components to advanced stability and security systems, every aspect is designed to protect both operator and machine in demanding environments. Clear sightlines, strengthened structure, and well-positioned safety aids further enhance operator awareness, reducing risk and supporting confident decision-making on busy worksites.

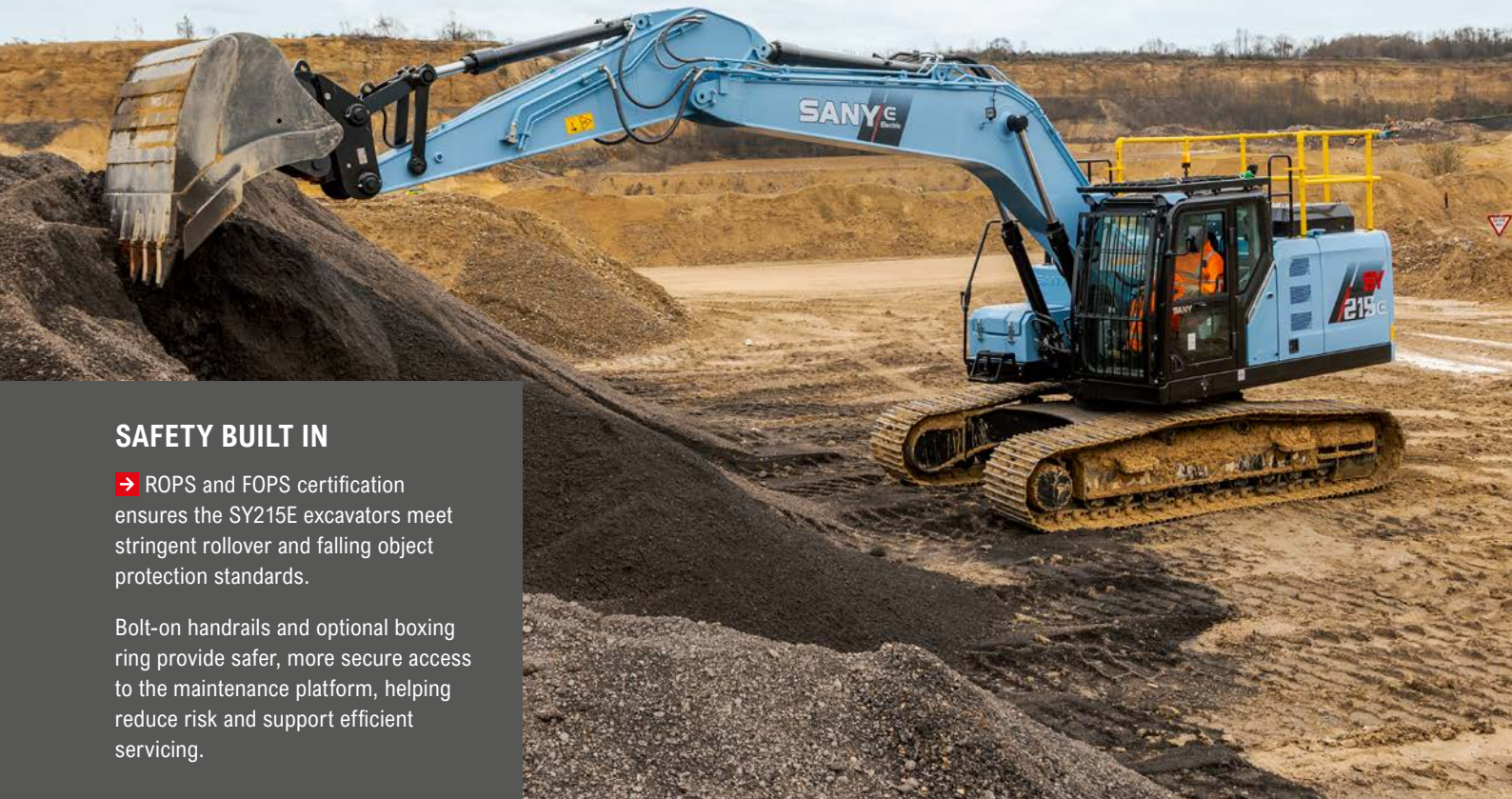

SAFETY BUILT IN

→ ROPS and FOPS certification ensures the SY215E excavators meet stringent rollover and falling object protection standards.

Bolt-on handrails and optional boxing ring provide safer, more secure access to the maintenance platform, helping reduce risk and support efficient servicing.

PROTECTING BYSTANDERS

Energy efficient LED work lights are positioned on the front of front of cab, rear, boom and platform for maximum versatility in poor or low light conditions.

A travel alarm and rotating warning beacon help make the machine more visible and noticeable on site, improving awareness and supporting safer working around the machine.

A combination of large mirrors and a rear camera, gives operators greater awareness of their surroundings for safer, more controlled operation.

EMERGENCY SHUTDOWN

Featuring both a battery disconnect switch and an emergency stop button, the system allows immediate power isolation to enhance operator and site safety.

ADVANCED SECURITY

Lockable service doors protect critical components and battery systems, preventing unauthorised access and enhancing site security.

Backed by the CESAR Datatag Scheme for proven theft deterrence and equipped with CESAR ECV, these machines allow swift and dependable verification of emissions category.

← Advanced anti-theft EVI telematics employ GPS tracking and configurable geofencing, this along with a password protected keyless stop/start function, safeguard the machine from theft and unauthorised use.



SY215E

SERVICE & MAINTENANCE

Designed for maximum uptime, SANY electric excavators combine a fully electric drivetrain with significantly reduced maintenance requirements. With fewer moving parts, no engine or aftertreatment systems, and extended service intervals, routine servicing is simpler, faster and more cost-effective. Easy-access service points and high-quality components throughout the machine further enhance reliability, helping ensure consistent, dependable performance shift after shift.



MAINTENANCE MADE EASY

← SANY excavators are engineered for streamlined service and maintenance, with design features that make routine upkeep faster and more efficient.

A fully electric drive with a reduced number of serviceable machine parts, reduces maintenance downtime and servicing costs.

A wide-opening service door provides ground-level access to all key service points, ensuring that daily checks are quick, simple, and easy to perform whilst ergonomic handrails enable safe access to the maintenance platform.

ROBUST STRUCTURES

Integrated guarding for the hydraulic cylinders provides robust protection against on-site impacts, minimising the risk of component damage, unplanned downtime, and expensive repair work.

COMMON, PREMIUM COMPONENTS

→ Produced in advanced manufacturing facilities in China, SANY excavators are built for high quality and lasting durability, utilising high-spec components from reputable global manufacturers.

Shared componentry across the range, combined with an extensive European dealer network, ensures rapid response and efficient turnaround for any machine repair.

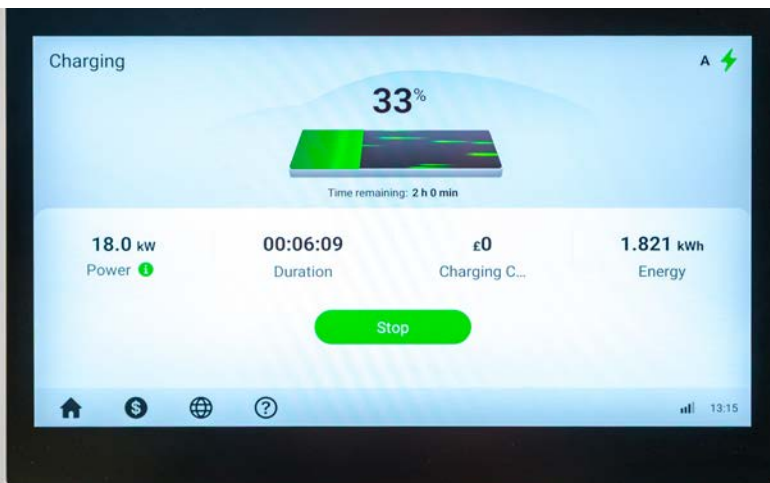

INCREASED WORKING HOURS

← With 500-hour service intervals, maintenance frequency is reduced, lowering operating costs and improving machine availability.

The lithium-iron phosphate battery equipped with BMS (battery management system) and thermal management ensures battery life and quality during operation and charging.

Real-time health alerts, remote diagnostics, and scheduled maintenance via SANY EVI telematics work together to enhance reliability and extend machine life.

SY215E

ATTACHMENTS

SANY machines offer extended capability through a broad selection of easily interchangeable attachments. This range enables efficient performance across varied tasks such as digging, drilling, land clearing, material handling, and demolition.

BUCKETS

↓ SANY provides a complete range of excavator buckets designed to enhance your machine's efficiency. From general-purpose digging buckets to more specialised options, they enable you to tackle a wide variety of job sites.

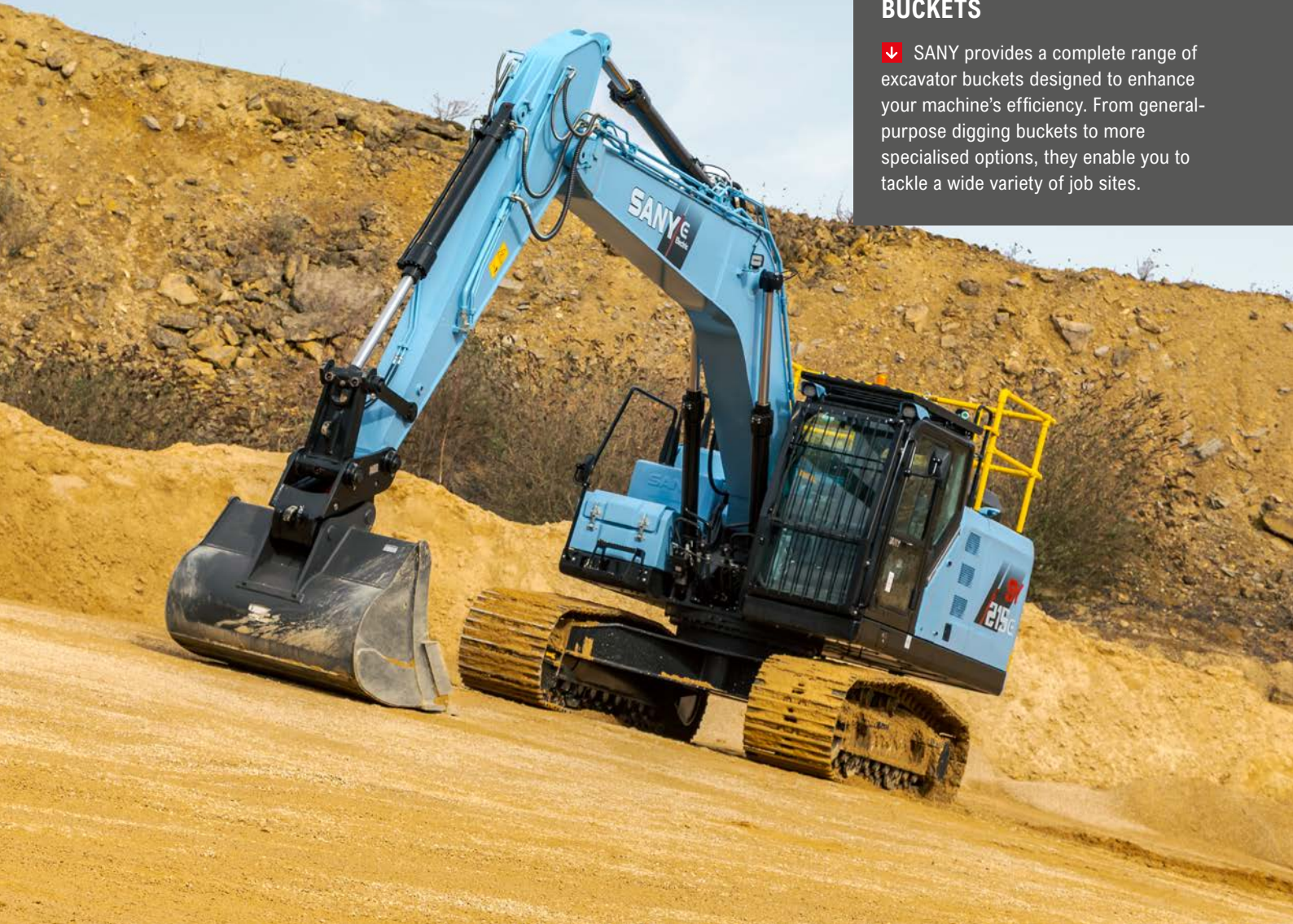

QUICK HITCH

↑ Equipped with quick hitches as standard, SANY machines enable rapid attachment changes, helping you get more done in less time. By reducing manual labour and ensuring a secure fit, they expand the machine's versatility and keep your operations running smoothly.

BREAKERS

SANY breakers have been designed to deliver powerful breaking performance, long-lasting durability, and high efficiency. They are suitable for a wide range of applications such as quarry, tunneling, civil construction, trenching, road & landscaping etc.

GRABS

SANY excavator grabs deliver powerful, reliable material handling with high clamping force, smooth hydraulic control and durable steel construction. The result is a cost-effective, high-performance attachment that boosts productivity and control on every job.*

*SANY attachment options may vary depending on country.

SY215E

YOUR UPTIME. OUR PRIORITY.

Rely on SANY's value-added aftermarket services to keep your equipment operating at peak efficiency. From proactive maintenance to reducing unexpected downtime and controlling operating costs, we provide the support your business depends on. Our European service solutions further boost performance, streamline maintenance tasks, and improve profitability across your fleet.

5 YEAR WARRANTY

Built on a global reputation for reliability and durability, SANY excavators come with an unmatched 5-year warranty* – one of the strongest in the industry.

It's a clear statement of the confidence we have in our machines and our commitment to your uptime. Your investment is protected from day one, giving you the assurance that if an issue arises, you're fully covered.

*Terms and conditions apply.

SERVICE AND SUPPORT

SANY's extensive network of certified technicians and dealer partners provides on-site service and technical expertise designed to minimise downtime and maintain peak machine performance.

Working in coordination with our advanced manufacturing facilities in China, our European teams combine global engineering capability with practical local support.

SANY GENUINE PARTS

SANY genuine parts are engineered, rigorously tested, and manufactured to the exact specifications required by your machine. Their precise fit and compatibility guarantee maximum performance and system integrity.

By maintaining correct operational tolerances, they enhance on-site safety and significantly reduce the risk of unplanned failures or downtime. All genuine parts are supported by a 12-month warranty for added assurance.



SY215E

INTELLIGENT SUPPORT

SANY's connected tools give you clarity, confidence, and control on every project. ROOTPILOT brings precision to the bucket; EVI Telematics brings visibility to the fleet. Together, they reduce downtime, cut costs, and boost productivity. Smart technology – driving your success.



Designed exclusively for Europe, our digital fleet management system EVI gives you complete visibility of your machines whenever and wherever you need it. By simplifying fleet oversight, it enables better decision-making, lowers costs, and improves uptime across your operations. With built-in safety and security features that let you monitor location and usage in real time, you gain greater control and peace of mind.

Key benefits include:

- Enhanced fleet visibility and remote machine management
- Set authorised operating hours and create geofenced security zones to reduce theft risk and misuse
- Greater visibility of routine checks and machine health
- Multi-channel, real-time communication for faster decision-making
- Operating report analysis for smarter, data-led decision-making
- Customer account management for personalised, data-backed communication



SANY ROOTPILOT is a high-precision 3D machine-control system that uses GNSS, IMU sensors, and smart algorithms to guide excavators in real time. It gives operators clear, intuitive 3D feedback for faster, safer, and more accurate digging.

ROOTPILOT installs quickly, works with multiple machines and attachments, and syncs designs through the cloud so every operator works from the same plan. It's ideal for highways, municipal works, and foundation projects where precision is critical.

Available in Fundamental and Premium versions, ROOTPILOT supports everything from basic grading to full 3D model guidance, offsets, layer control, and complex digital designs.

Main customer benefits:

- ±3 cm accuracy for first-time-right excavation
- Avoidance of underground utilities and hazards
- Lower fuel, labour, and rework costs
- Faster production with fewer survey checks
- Works with 2D or full 3D design models
- Boosts operator confidence and consistency

SY215E

SPECIFICATION

POWER SYSTEM

Model	Vmax
Battery type	LFP - Lithium-iron phosphate battery (cobalt free)
Motor type	Permanent magnet synchronous motor
Max. rated power	150 Kw / 1,800 rpm
Max. torque	1500 Nm
Rated voltage	618 V
Aux battery voltage	2 x 12 V
Rated capacity	120 Ah
Fully charged battery capacity	422 kWh
Charge Time	DC fast charge (320kw dual gun charger) - 1.5 hrs Industrial 3 Phase 63 Amp (40Kw charger) - 8-10 hrs
Run time (dependng on application)	5-8 hrs

HYDRAULIC SYSTEM

Main pump	Variable-displacement axial piston pumps with electronic control.
Max. oil flow	2 x 222 l/min

PERFORMANCE

Swing speed	12 rpm
Max. travel speed	High 5.4 km/h
Max. travel force	220 kN
Gradeability	70%/35°
Bucket capacity	1.1 m³
Ground pressure	47 kPa
Bucket digging force (ISO)	138 kN
Arm digging force (ISO)	103 kN

SERVICE REFILL CAPACITIES

Hydraulic oil tank	230 l/min
--------------------	-----------

OPERATING WEIGHT

23,200 kg
Note: Includes 75kg (165 lb) operator, and excludes any attachments or hitch.

UNDER & UPPER STRUCTURE

Boom length	5,700 mm
Arm length	2,925 mm
Bottom rollers	8
Top rollers	2
Rotation device	Axial piston motor, planetary gear, single row slewing ring, hydraulic parking brake.
Undercarriage	Reinforced undercarriage. Welded drive frame.

RELIEF VALVE SETTINGS

Implement circuit	34.3 MPa
Swing circuit	25.5 MPa
Travel circuit	34.3 MPa
Pilot pressure	3.9 MPa

SOUND LEVEL

Noise level inside cabin	71 dB(A)
Noise guaranteed value	97 dB(A)

Based on theoretical calculation at max flow with no load.

Subject to alterations.

In the interest of continual equipment development, SANY reserves the right to change these specifications at any time without prior notification.

SY215E

SPECIFICATION

LIFTING CAPACITIES

Load Point Height (B)	Radius (A)								Digging Reach	
	3.0 m		4.5 m		6.0 m		7.5 m		Max	
7.5 m kg					4439.18	4439.18			3142.46	3142.46
6.0 m kg					5210.52	4631.08			3143.33	3143.33
4.5 m kg					5905.03	4466.82	4636.06	3133.94	3099.06	2783.40
3.0 m kg			8686.56	6388.90	6380.68	4225.13	4523.84	3031.00	3182.79	2540.63
1.5 m kg			9504.66	5894.40	6112.18	3985.70	4396.98	2914.62	3381.35	2450.68
Ground line kg	6663.30	6663.30	9129.42	5577.90	5922.25	3816.32	4296.37	2822.33	3717.27	2494.18
-1.5 m kg	10709.00	10353.90	9085.85	5541.20	5840.95	3743.83	4275.64	2803.31	4110.75	2703.05
-3.0 m kg	16361.00	10539.80	9156.21	5600.50	5882.45	3780.84			4996.22	3295.60
-4.5 m kg	14692.00	10913.00	9415.98	5819.60					6959.28	4477.58

1. This capability is calculated according to GB/T 13331, ISO10567 standards. The limiting coefficient of the hydraulic system is 0.87, and the tipping coefficient is 0.75.
2. Marked with * is limited by hydraulic pressure, marked without * is limited by stability.
3. The lifting point is the support hole in front of the bucket rod (excluding the weight of the bucket). If there are additional accessories such as buckets, they should be deducted from the above lifting weight.
4. A- Radius of loading point (m), B- Loading point height (m).

SY215E

SPECIFICATION

DIMENSIONS (TRANSPORT)

A	Transport length	9,910 mm
B	Transport width	2,980 mm
C	Height over cabin / ROPS	3,075 mm
D	Cab width	2,875 mm
E	Track height	923 mm
F	Track width	600 / 700 mm
G	Track gauge	2,380 mm
H	Min. ground clearance	440 mm
I	Tail swing radius	3,125 mm
J	Track ground length	3,445 mm
K	Track length	4,250 mm
L	Counterweight clearance	1,130 mm
M	Height of boom – transport	3,440 mm
N	Undercarriage width	2,980 mm
	Engine cover height	2,630 mm

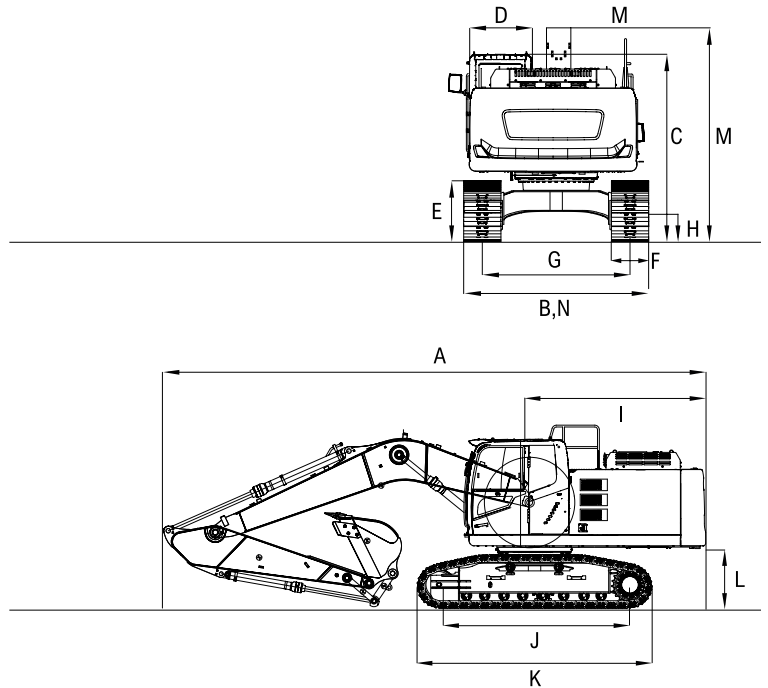

WORKING AREA

A	Max. digging height	9,600 mm
B	Max. dumping height	6,730 mm
	Min. dumping height	2,392 mm
C	Max. digging depth	6,255 mm
D	Max. digging reach	10,280 mm
E	Min. swing radius	3,730 mm
F	Maximum height at minimum swing radius	7,680 mm
	Max. vertical digging depth	6,225 mm

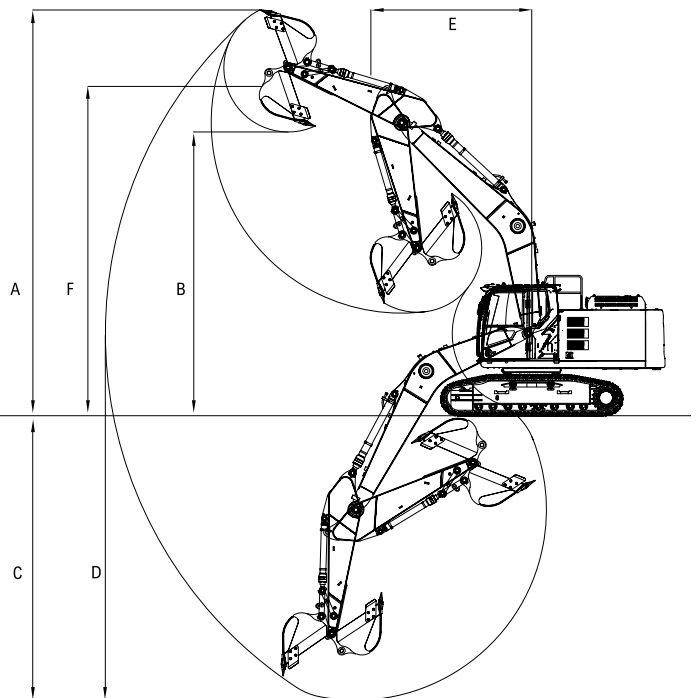

SY215E

STANDARD/OPTIONAL EQUIPMENT

OPERATORS COMFORT / CAB

	SY215E
Heated air suspension seat	•
Heater	•
Air conditioning system	•
Bluetooth radio & speaker	•
USB socket (music)	•
Adjustable armrests	•
10" smart touch screen	•
12V outlets	•
Wiper	•
Sun shade	•
AUX 1 on joystick	•
AUX 2 on joystick	•
Stored hydraulic settings for attachments	•
Cup holder	•
Storage compartment	•

WORKING LIGHTS

	SY215E
2 x LED lights – front	•
2 x LED lights – boom	•
1 x LED light – platform	•
1 x LED light – rear	•
Magnetic beacon	•

UNDERCARRIAGE

	SY215E
Steel tracks 600 / 700 mm	OPT
Cylinder guards – dozer blade	•
Holes / loops for fixing	•

SAFETY & SECURITY

	SY215E
ROPS and FOPS cab	•
Battery master switch	•
Travel alarm	•
Emergency stop button	•
Retractable seatbelt	•
Rear camera	•
360° camera	OPT
Rear window emergency exit	•
Bolt-on handrail	•
Lockable bonnet	•
All-round mirrors	•
EVI telematics	•
Boxing ring	OPT

WORKING EQUIPMENT

	SY215E
Boom and arm load holding valves with overload indicator	•
Cylinder guards – boom	•
Double acting circuit for hydraulic quick coupler with piping	•
Breaker & shear line proportional on joystick with piping	•
Rotation line proportional on joystick with piping	•
Flow adjustment for attachments	•
40 kW Onboard Charger	OPT

HYDRAULIC SYSTEM

	SY215E
Swing brake	•
2 speed travel	•
Hydraulic pre-pressure operating joysticks	•
Piping for AUX 1 circuit	•
Piping for AUX 2 circuit	•

The standard and optional equipment can differ depending on the country in which the machine is delivered. Please contact your local dealer for more information.



SANY HEAVY MACHINERY (UK) LTD
Unit 6, M8 Interlink Estate,
Coatbridge, Glasgow, ML5 4RP
Tel: 0330 2021 318
Email: info@sanyuk.com

Sanyuk.com

Not all products are available in all markets.
As part of our continuous improvement process,
we reserve the right to modify specifications and
designs without giving prior notice. Machines
shown may feature additional options other than
the standard machine specification.

HEX - SY215E - 05.2026 - EU - V1