

# SANY<sup>®</sup>

QUALITY CHANGES THE WORLD



13.6 t



16.5 m



21.1 m

## SCD150

Excellent Assistant  
for In-Plant Maintenance

# SANY CRANE

BETTER WORLD, BETTER SANY CRANE



SANY CRANE is one of the core business units in SANY Group, specializing in the development and manufacturing of high-end wheeled cranes, crawler cranes.



# CONTENTS

---

Crane Overview	▶ 04
----------------	------

---

Highlights	▶ 04
------------	------

---

Overall Dimensions	▶ 06
--------------------	------

---

Technical Specifications	▶ 07
--------------------------	------

---

Machine Introduction	▶ 09
----------------------	------

---

Working Conditions & Code Description	▶ 11
T	12
TJ	17

---

Icon Description	▶ 18
------------------	------

---

SANY Overseas Service	▶ 19
-----------------------	------

## HIGHLIGHTS

### Working in narrow spaces

Overall height of 2.5m, width of 2.39m, easily fits through factory buildings dockyard.

New single-stage oblique outriggers, strong adaptability to different terrains.

All-wheel steering with a minimum steering radius of 3.5m, approach angle 20° and departure angle 19°, strong accessibility.

Three-position mechanically offset (0°, 15° and 30°) of boom nose.

The superstructure allows free slewing, enabling precise operation in narrow spaces such as building windows.

### Strong lifting capability

Hexagonal large-section 4-section boom with 16.5m full-extension boom and 4.6m standard jib, max. lifting height 20.1m, leading configuration in the industry.

Max. lifting moment of basic boom 334kN.m, max. lifting capacity of full-extension boom 5.5t, working radius 1.8m~15.4m, leading performance in the industry.

3.7m transverse outrigger span, 1.7t counterweight, comprehensive leading capacity in the industry.

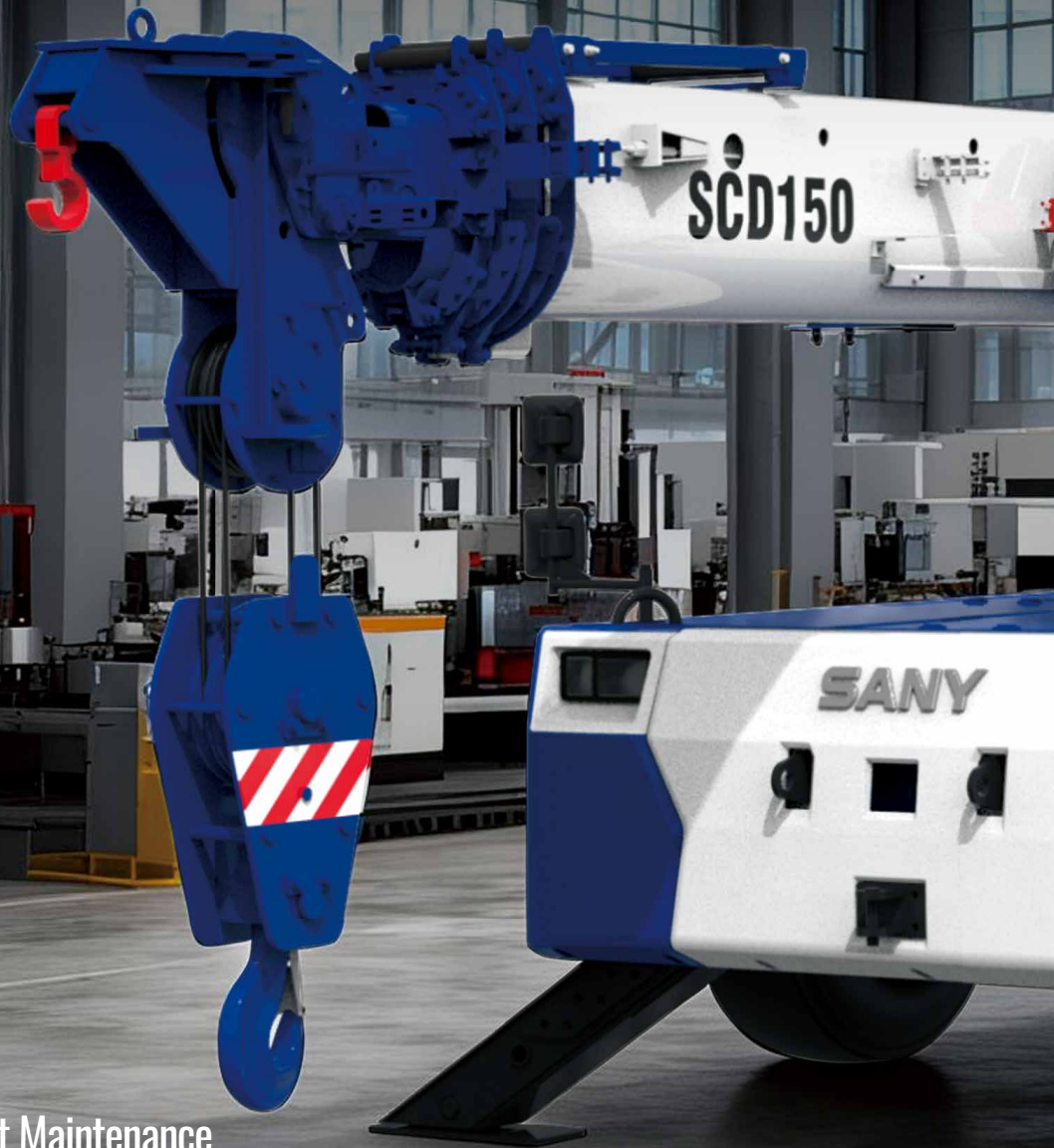

Excellent Assistant for In-Plant Maintenance  
**SCD150 / 13.6t Lifting Capacity**

## Traveling with load

The crane is able to travel with 5.2t load at dead front on its base boom.

## Multiple working condition options

Selectable boom, jib, traveling with load and others working configurations.

Steel walking surfaces and stepping surfaces, capable of short-distance handling and self-loading/unloading within the factory area, saving one flatbed truck.

## Brand-new driving experience

Industry-first pillar-free chamfered cab design expands interior space by 18%, offering enhanced visibility and easier access. Front rigid suspension and rear oscillation suspension. It can adapt to various harsh working conditions and road surfaces, ensuring smooth vehicle operation and stability against rollovers.

Equipped with six HD cameras, the operator gains full awareness of the surroundings. With on-crane wireless remote control, key functions—boom telescoping, luffing, slewing, and hook lifting—can be precisely managed from the optimal outside vantage point, greatly enhancing safety, responsiveness, and operational confidence in complex conditions.



# OVERALL DIMENSIONS

Unit: mm

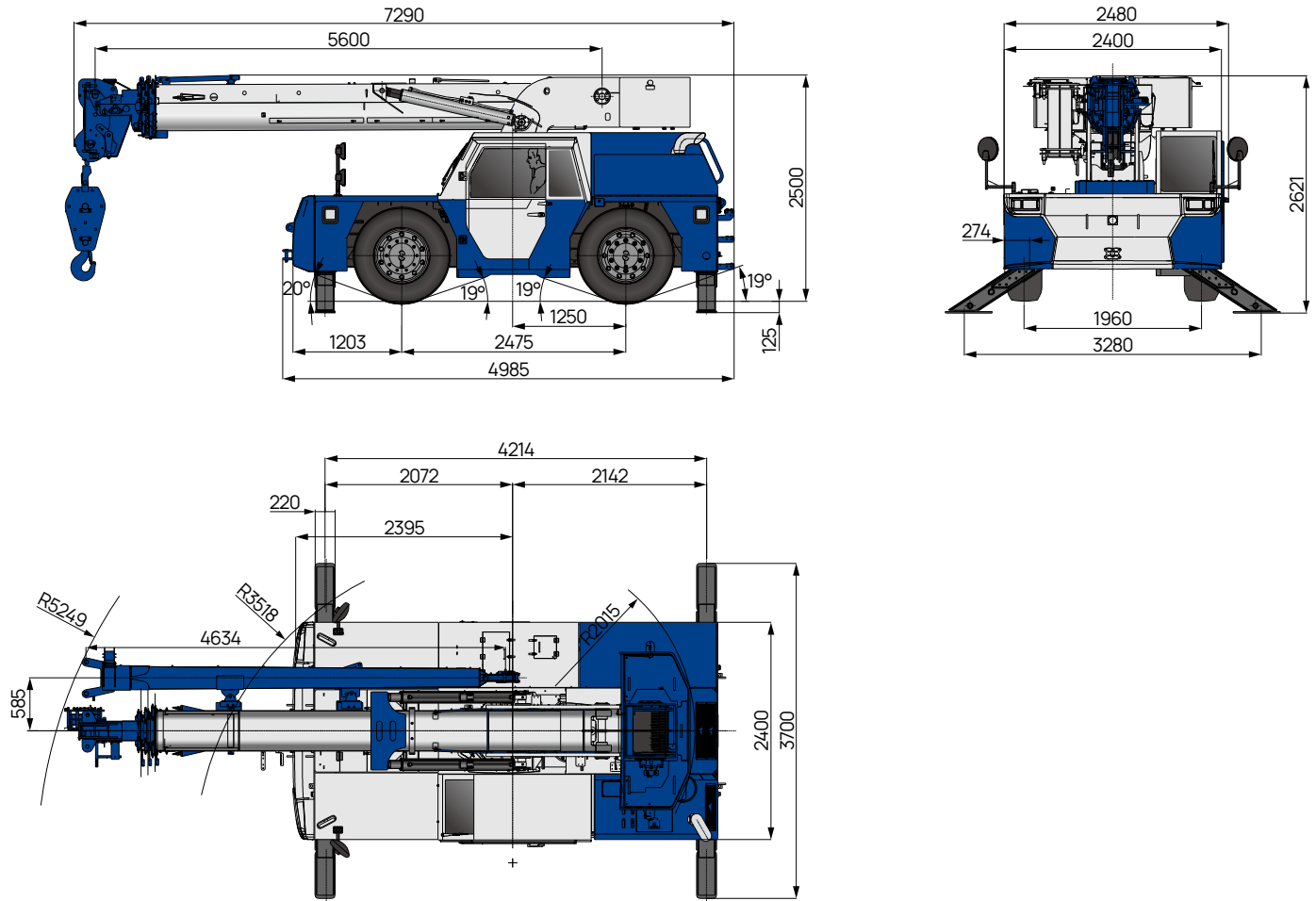



# TECHNICAL SPECIFICATIONS

CATEGORY	ITEM	UNIT	VALUE	
CAPACITY	Max. rated lifting capacity	t	13.6	
WEIGHT	Gross weight	kg	14900	
	Fixed counterweight	kg	1700	
POWER	Engine model	-	F3.8 (Euro V)	
	Max. engine power	kW/rpm	90/2200	
	Max. engine torque	N·m/rpm	500/1500	
DIMENSIONS	Overall length	mm	7290	
	Overall width	mm	2400	
	Overall height	mm	2500	
	Wheelbase	mm	2475	
	Track width	mm	1960	
TRAVEL	Max. travel speed	km/h	25	
	Min. steering radius	m	3.5	
	Approach angle	°	20	
	Departure angle	°	19	
MAIN PERFORMANCE	Min. rated lifting radius	m	1.8	
	Tail slewing radius	mm	2000	
	Max. lifting moment	Main boom	kN·m	334
		Full-extension boom	kN·m	298
		Full-extension boom + jib	kN·m	191
	Boom length	Main boom	m	5.6
		Full-extension boom	m	16.5
		Full-extension boom + jib	m	21.1
	Max. lifting height	Main boom	m	5.5
		Full-extension boom	m	16.0
		Full-extension boom + jib	m	20.6
Outrigger span (Longitudinal × Transverse)	m	4.2 × 3.28		
Adjustable boom nose	°	-30/-15/0/40/80		





# TECHNICAL SPECIFICATIONS

## ■ Axle Load

	1	2	
Axle load /t	7600	7100	14900









Remark: Full configuration, with one operator.

## ■ Hook

			 kg	
13.6	2	4	160	●
5	-	1	80	●

● Standard ○ Optional

## ■ Operations

			 L	 F
	0~50m/min	Φ14mm	100m	4t
	0~2.1r/min			
	30/36s			
	23/22s			

# MACHINE INTRODUCTION

## ■ Carrier

### Driver's cab

- Sany independently developed cab, designed based on ergonomic principles, with excellent shock absorption and sealing properties. It is equipped with a two-point safety belt, an adjustable multifunction steering wheel, and automatic heating and cooling air conditioning. 10.1-inch display screen, providing a comprehensive view of the vehicle's status. The button panel is fully functional, enhancing the driving experience for comfort, safety, and user-friendliness.
- Industry-first pillar-free chamfered cab design expands interior space by 18%, offering enhanced visibility and easier access.

### Carrier frame

- Sany double longitudinal beam construction welded by high-strength fine-grained high-strength steel plate, higher bearing capacity and longer service life.

### Axle

- All-wheel steering, with the front axle serving as the driving axle, offers light and flexible steering, thereby enhancing maneuverability and agility.

### Engine

- Model: Inline four-cylinder diesel engine with watercooler and inter cooler.
- Environmental-friendly: Cummins engines can provide emission power solution tailored to the needs of different countries and regions, meeting the emission standards Euro Stage V.
- Fuel reservoir capacity: 150L.

### Transmission

- Integrated Manual and Automatic Transmission, 3 forward gears and 3 reverse gears. Smooth gear shifting.

### Suspension system

- Front axle suspension and rear axle with cylinder locking pivot swing suspension.

### Steering

- Hydraulic cylinder steering.
- Equipped with multiple steering modes to achieve higher maneuverability, and the minimum steering radius is 3.5m.

### Brake

- The braking system includes service brake & parking brake.
- Wet-type brakes offer rapid braking response and high braking efficiency.

### Wheel formula

- 4×2.

### Outrigger

- Single-stage oblique outriggers, strong adaptability to different terrains.
- Axle articulation structure with adjustable angles to adapt to different ground conditions.

### Tires

- 385/65R22.5.

### Electrical system

- Utilizing an internationally advanced distributed integrated bus data communication network, the system ensures high-speed information transmission with a response time of less than 20ms.
- Equipped with a 10.1-inch high-definition display screen featuring a new user interface. Various work statuses can be displayed through button indicator lights.
- Sany independently developed a Load Moment Indicator with precision up to 0~5%.
- The winch camera monitors the winch operation, promptly detecting any rope disorder problem.

# MACHINE INTRODUCTION

## ■ Superstructure

### Slewing platform

- SANY independently developed, made of fine grain high strength steel in optimized structure.

### Boom system

- Boom: Four-section, basic boom 5.6m, full-extension 16.5m, made of fine-grained high-strength welded steel plates. Single cylinder telescoping with rope arranger functioning automatic telescoping, with a double-acting cylinder that can control the extension and retraction of all boom sections, achieving various combinations of boom lengths.
- Jib: 4.6m jib with adjustable jib head, offset at 0°, 15°, 30°.

### Luffing system

- Luffing angle: 0° ~75°, electric proportional control, combining power luffing with passive luffing, it can achieve rapid luffing at large angles and stable, slow-speed luffing at small angles.

### Hoist

- High-quality wire rope locks enhances the efficiency of changing the wire rope ratio, making it convenient and swift.
- Specifications:  $\phi 14$ , 35WxK7 anti-rotation steel wire rope.
- Max. single rope speed: 50m/min.

### Hydraulics

- Load-sensitive superstructure hydraulic system, achieving high-precision flow control to maximize energy efficiency. The boom extension and retraction system uses an open system composed of an electronically controlled proportional pump and a proprietary main valve. The hoist and winch systems, as well as the slewing system, adopt open systems.
- All key components, including hydraulic pumps, piston motors, and balance valves, are sourced from top-tier international brands, ensuring high quality and reliability. Sany's independently developed double pump intelligent flow distribution system.

### Slewing

- 360° slewing in both direction, max. speed 2.1 rpm. The slewing adopts a open system for stable braking.

### Control system

- Powered by a 24V DC power supply, and controlled by a CAN-BUS control network.
- The system features real-time monitoring and automatic fault diagnosis capabilities.

### Safety equipment

- Analytical mechanics is applied and load moment indicator calculation system based on the hoisting mechanics model is established. Through online empty-load calibration, the rated accuracy can reach 0~5%.
- The hydraulic system includes balance valve, relief valve, two-way holding valve, etc. to realize system stability and reliability.
- The main and auxiliary winches are equipped with third-wrap indicators to prevent over-hoist-down of the wire rope.
- Boom head and jib head are equipped with A2B switches to prevent the wire rope from over winding.



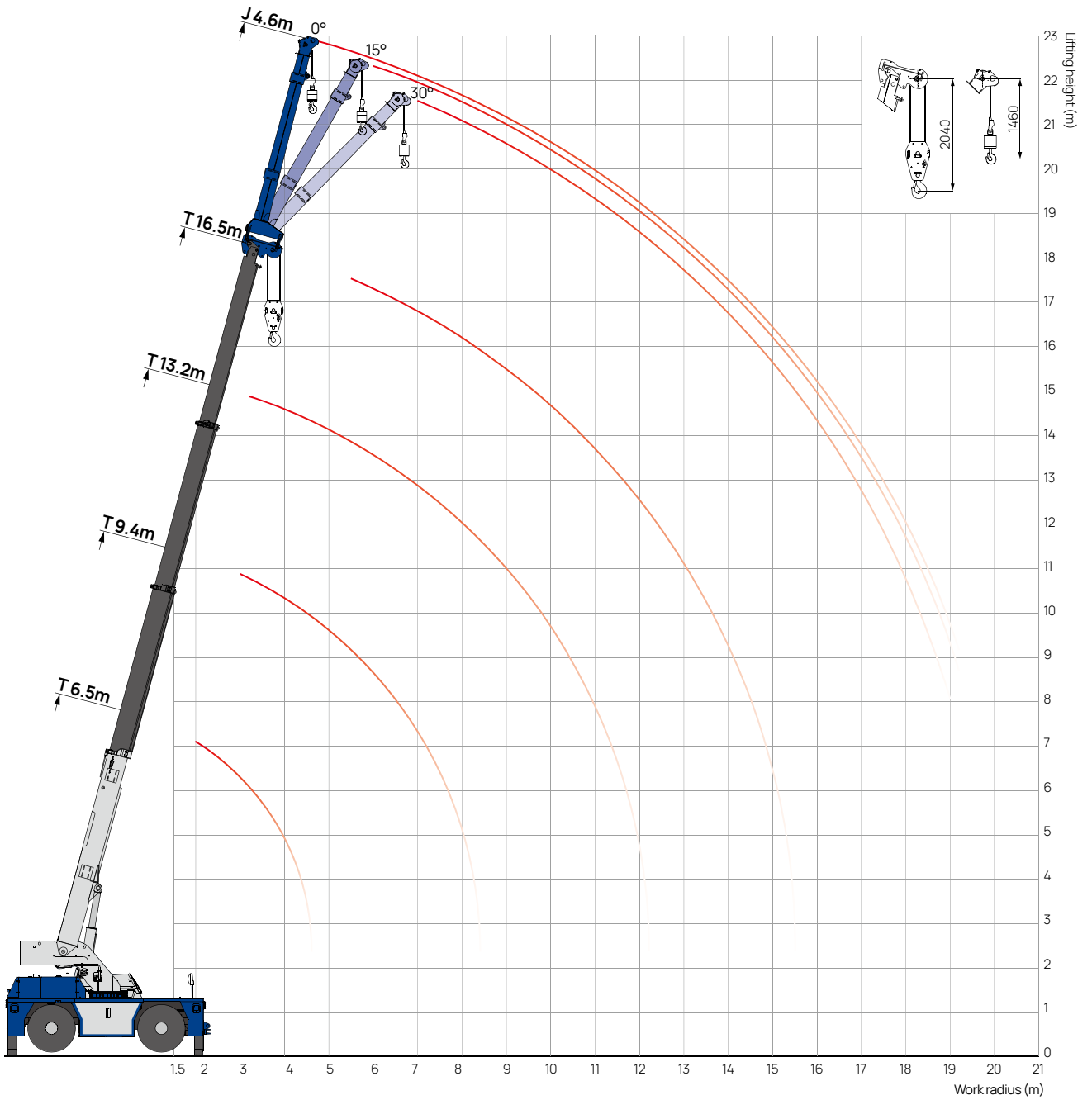

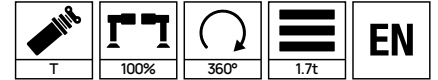

# OPERATING RANGE - TJ



# LOAD CHART - Telescopic Boom (T), 360° Slewing









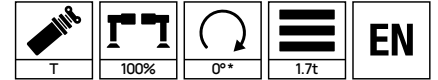



Unit: kg

	5.6	9.4	13.2	16.5	
1.8	13600				1.8
2.4	11900				2.4
3	9800	7800			3
3.7	8600	7800			3.7
4.3	6200	7100	7000		4.3
4.9		5700	5800		4.9
5.5		4700	4700	4700	5.5
6.1		3800	4000	3900	6.1
6.7		3300	3400	3400	6.7
7.3		2900	3000	2900	7.3
7.9		2400	2600	2600	7.9
8.5			2300	2300	8.5
9.1			2000	2000	9.1
9.8			1800	1800	9.8
10.4			1600	1600	10.4
11			1400	1400	11
11.6			1200	1300	11.6
12.2				1200	12.2
12.8				1100	12.8
13.4				1000	13.4
14				900	14
14.6				800	14.6
15.2				700	15.2
15.4				600	15.4
	0	0	0	0	
	3000	1500	800	300	

# LOAD CHART - Telescopic Boom (T), Load Over Front









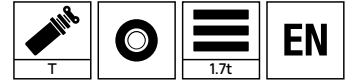

Unit: kg

 m	5.6	9.4	13.2	16.5	 m
1.8	13600				1.8
2.4	11900				2.4
3	9800	7800			3
3.7	8600	7800			3.7
4.3	6200	7500	7000		4.3
4.9		6800	6300		4.9
5.5		6200	5800	5500	5.5
6.1		5300	5200	5000	6.1
6.7		4500	4400	4400	6.7
7.3		3900	3800	3800	7.3
7.9		3000	3300	3300	7.9
8.5			3000	2900	8.5
9.1			2700	2600	9.1
9.8			2400	2300	9.8
10.4			2100	2100	10.4
11			1900	1900	11
11.6			1800	1700	11.6
12.2				1600	12.2
12.8				1500	12.8
13.4				1400	13.4
14				1300	14
14.6				1200	14.6
15.2				1100	15.2
15.4				1000	15.4
 Min  kg	0	0	0	0	 Min  kg
 Min  kg	3000	2000	1000	500	 Min  kg

# LOAD CHART - Telescopic Boom, On Tires Stationary, Load Over Front



Unit: kg

 m	5.6	9.4	13.2	16.5	 m
1.8	7100				1.8
2.4	5800				2.4
3	4800	4800			3
3.7	3500	3700			3.7
4.3	2700	2900	3000		4.3
4.9		2300	2400		4.9
5.5		1900	2000	2000	5.5
6.1		1600	1700	1700	6.1
6.7		1400	1400	1500	6.7
7.3		1200	1200	1300	7.3
7.9		1000	1100	1100	7.9
8.5			900	1000	8.5
9.1			800	800	9.1
9.8			700	700	9.8
10.4			600	600	10.4
11			500	500	11
11.6			400	500	11.6
12.2				400	12.2
12.8				400	12.8
13.4				300	13.4
14				300	14
 Min	0	0	18	25	 Min
 Min kg	1500	500	300	200	 Min kg
 Max	75	75	75	75	 Max

# LOAD CHART - Telescopic Boom, On Tires Stationary, 360° Slewing

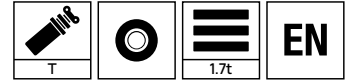









Unit: kg

m	5.6	9.4	13.2	16.5	m
1.8	6400				1.8
2.4	4600				2.4
3	3200	3400			3
3.7	2300	2500			3.7
4.3	1800	1900	2000		4.3
4.9		1600	1600		4.9
5.5		1300	1300	1500	5.5
6.1		1000	1100	1100	6.1
6.7		800	900	900	6.7
7.3		700	700	800	7.3
7.9		500	600	700	7.9
8.5			500	600	8.5
9.1			400	500	9.1
9.8			300	400	9.8
10.4			300	300	10.4
Min kg	0	20	30	46	Min kg
Max kg	800	300	200	200	Max kg
Max kg	75	75	75	75	Max kg

# LOAD CHART - Telescopic Boom, Pick & Carry, Load Over Front









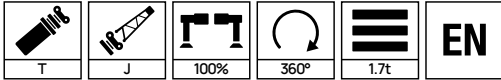

Unit: kg

 m	5.6	9.4	13.2	16.5	 m
1.8	5200				1.8
2.4	4200				2.4
3	3500	3600			3
3.7	2900	3000			3.7
4.3	2400	2500	2600		4.3
4.9		2000	2200		4.9
5.5		1700	1800	1800	5.5
6.1		1400	1500	1500	6.1
6.7		1200	1300	1300	6.7
7.3		1000	1100	1200	7.3
7.9		900	1000	1000	7.9
8.5			800	900	8.5
9.1			700	800	9.1
9.8			600	600	9.8
10.4			500	500	10.4
11			400	500	11
11.6			300	500	11.6
12.2				400	12.2
12.8				400	12.8
13.4				300	13.4
 Min	0	0	18	29	 Min
 kg	1200	400	200	200	 kg
 Max	75	75	75	75	 Max









































































# LOAD CHART - Fixed Jib



Unit: kg

 m	16.5+4.6			 m
	0°	15°	30°	
4.9				4.9
5.5				5.5
6.1	3200			6.1
6.7	2800			6.7
7.3	2600	2200		7.3
7.9	2400	2100	1700	7.9
8.5	2200	2000	1600	8.5
9.1	2100	1900	1600	9.1
9.8	1900	1800	1500	9.8
10.4	1700	1700	1500	10.4
11.0	1500	1600	1500	11.0
11.6	1400	1400	1400	11.6
12.2	1300	1300	1300	12.2
12.8	1200	1200	1200	12.8
13.4	1100	1100	1100	13.4
14.0	1000	1000	1000	14.0
14.6	900	900	900	14.6
15.2	800	800	800	15.2
15.8	700	700	800	15.8
16.5	700	600	700	16.5
17.1	600	600	600	17.1
17.7	500	500	500	17.7
18.3	500	500	500	18.3
18.9	400	400	400	18.9
 Min  kg	18	20	21	 Min  kg
 Min  kg	200	200	200	 Min  kg

# ICON DESCRIPTION

 Max. lifting capacity	 Max. boom length	 Max. lifting radius	 Max. lifting height	 Driver's cab
 Carrier frame	 Engine	 Transmission	 Transfer case	 Axle
 Outrigger	 Slewing platform	 Suspension system	 Steering	 Tires/Tire size
 Wheel formula	 Transmission shaft	 Brake system	 Electrical system	 Hydraulic system
 Operator's cab	 Control system	 Hoist	 Slewing	 Safety equipment
 Load moment indicator	 Counterweight	 CW rearward positioned	 Boom & telescoping system	 Luffing system
 Jib	 Superlift device	 Wind power jib	 Luffing jib	 Auxiliary jib
 Boom extension	 Auxiliary boom nose	 Rear storage box	 Optional equipment at extra fees	 Motor
 Hybrid Powertrain	 Power battery			
 Axle load	 Weight	 Number of sheaves	 Min. Min. travel speed	 Max. Max. travel speed
 Max. gradeability	 Gear	 Onroad gear	 Crawl speed	 Hook
 Main hook	 Auxiliary hook	 Rope rate	 Max. supporting forces	 Outrigger pads
 Outrigger jack	 Outrigger beam	 Front outrigger	 Rear outrigger	 Hook weight
 Operations	 Max. single line lifting speed (empty load)	 Rope diameter	 Rope length	 Max. single line pull
 Main winch	 Auxiliary winch	 Full luffing up/down time of boom	 Full extension/retraction time of boom	 Anemometer
 Spare tire				

**SANY**<sup>®</sup>

**Crowland Cranes Ltd**  
**Crease Drove,**  
**Crowland,**  
**Peterborough,**  
**PE6 0BN**  
**United Kingdom**

**Tel:** +44 1733 210561  
**Email:** [sales@crowlandcranes.co.uk](mailto:sales@crowlandcranes.co.uk)  
**Web:** [www.crowlandcranes.co.uk](http://www.crowlandcranes.co.uk)



Contact SANY Group



Follow SANY Group